

FOBA®

Technology + Services

A **VIRTEK** Company

Laser systems for marking and engraving



In the field of Nd:YAG lasers, FOBA supplies basic systems with a power range of 15 to 100 Watts. Basic systems are suitable for universal use in machine workplaces, manufacturing lines or special machines.

With the diode-pumped **DP50** system we set new standards of efficiency and compactness in laser systems.

- Output power 50 Watt (CW)
- High beam quality
- Single-phase mains connection
- Closed cooling circuit without external cooling water
- Long working life of the laser diodes means little servicing
- DUAL DOUBLE HEAD-Technology
- Compact design means easy integration
- Powerful user-friendly software under MS Windows®



Area of application



Marking on almost all materials, mainly marking on plastics, lacquer removal (day and night design) and marking of electronic components; also suitable for engraving

DP50

Basic system - 50 Watt

Practical Brilliance in Lasers

DP50

Basic system - 50 Watt

System

Marking field	110 x 110 mm ²
Marking speed	up to 5000 mm/s up to 500 characters/s
Line width	100 µm (optionally 50 µm)

Laser

Laser type	Nd:YAG, 1064 nm, diode pumped
Power (CW)	50 W
Power (QS)	typical 10 kW/pulse (10 kHz)
Power stability	+/- 2 % (CW) +/- 5 % (QS, 1 - 7 kHz)
Output modes	Continuous wave operation (CW) Pulsed operation (QS), 0.1 - 65 kHz Mixed operation (parameterizable)
Aperture	Interchangeable aperture, 8 different diameters
Safety	Class IV Laser

Control

Control system	modular CompactPCI-PC with CAN-Bus
Operating system	MS Windows® 2000
Laser control	FOBAGRAF with import function of plt, dwg, dxf, ai, jpg, tif, pcx, bmp ...
Interfaces	serial, digital I/O, Ethernet, USB optionally: CAN, PROFIBUS

Installation

Electrical	1/N/PE AC 230V, +/- 10 %, 50/60 Hz
Power consumption	typ. 1.8 kW
Cooling system	Internal water/air cooler
Temperature	5 - 38 °C
Humidity	90 % (up to max. 20 °C), 30 % (up to max. 38 °C), non-condensing
Weight	Laser head approx. 21 kg Control cabinet approx. 170 kg
Degree of protection	IP 54

Options

Marking on the fly	for marking moving workpieces
Pointer	adjustment aid
Monitor	separate
Changeable lens	

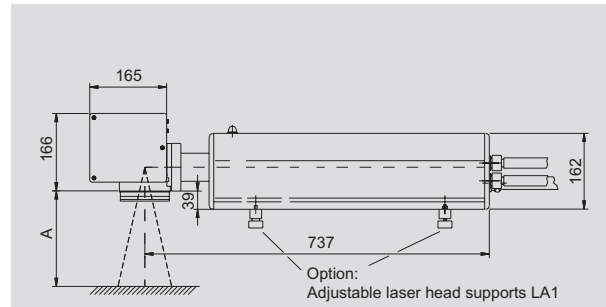

A....average working distance

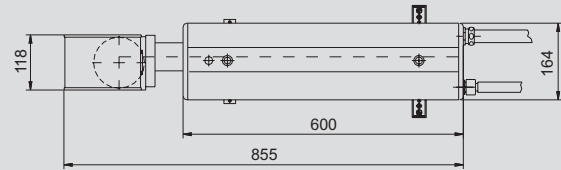

Laser head with standard scan head and lens

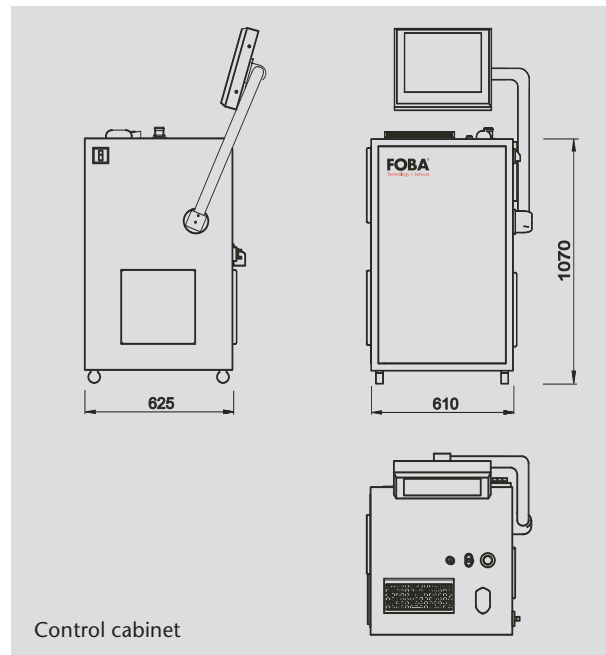

Control cabinet

FOBA[®]
Technology + Services
A **VIRTEK** Company

End to end excellence in laser systems



EUROPE

FOBA Technology + Services GmbH
www.foba.de
sales@foba.de

Postfach 15 60
D-58465 Lüdenscheid
Germany

Tel. +49 2351 996-0
Fax +49 2351 996-155

NORTH & SOUTH AMERICA

Virtek
www.virtek.ca
fobasales@virtek.ca

785 Bridge Street
Waterloo, ON N2V 2K1
Canada

Tel. +1 800 684-7835 or 519 746-7190
Fax +1 519 746-3383

ASIA

Virtek Asia Pacific Inc.
www.virtek.ca
asia.sales@virtek.ca

Eru Building, 2nd Floor
3-14-6 Higashikashiwayaya
Ebina City, Kanagawa, 243-0401, Japan

Tel. +81 46-292-0739
Fax +81 46-292-0793